

DiscoverE Engineers Week Bridge Contest Procedures and Rules

Contest Objective: Participants will design the most efficient bridge to span a 24" gap, maximizing load-carrying capacity and minimizing deflection and weight. **Review the rules below. See helpful diagrams on the reverse side for further details.**

REGISTRATION REQUIRED FOR PARTICIPATION

Participation may be as an individual or as a team. Teams: up to three team members
Each participant must **register individually even if a member of a team.**
On the day of competition, participants bring a signed Honor Form and Media Consent Form signed by parents/guardians if the individual is under 18 years.

Rule 1 ALLOWABLE MATERIALS

- A. **Glue: wood glue only (ex. Elmer's®)**
- B. **Wooden craft sticks (ex. Popsicle®)**
- **Maximum number of sticks: 200**
 - **Size of sticks: standard sized sticks ONLY** with dimensions of 3/8 Wide X 4 1/2 Long; *Note: Jumbo sticks are prohibited*
 - **Sticks may be modified (i.e. soaked in water only, cut, bent, drilled, sanded, etc.)**
- C. **Natural stick color:** bridges cannot be painted or coated with any materials

Rule 2 DESIGN REQUIREMENTS

- A. **Bridge height** requirement: 12" or less
- B. **Bridge width** requirement: 6" or less
- C. **Bridge length** requirement: **longer than 24"** (approx. 26" is typically a good length) This allows the bridge to be set on top of the metal supports for testing. **See testing procedures***
- D. **Bridge opening #1:** The bridge must have at least a 2" X 2" opening at the top center allowing the loading arm to apply pressure on the bridge deck.
- E. **Bridge deck:** The bridge deck must have a minimum interior width of 3" and should provide sufficient decking support for loading during the test procedures. The deck need not be continuous but must be situated at the point of loading (the center of the 24" opening between metal supports. **See testing procedures***).
- F. **Bridge opening #2:** The bridge must be open at deck level to allow a 3" X 3" X 3" cube to pass through the bridge from one end to the other.
- G. **Bridge Truss requirement:** The bridge must have 2 parallel trusses. **Special Note:** trusses above the deck must be at least 3" apart to allow the cube to pass between them; trusses below the deck can be any width apart. If the trusses are below the deck, they need to clear the 24" wide opening between the metal supports in order to fit in the testing device.

TESTING PROCEDURE

The bridge sets in the testing device on top of two metal supports at either end of a 24" opening. In the center of this 24" gap, a metal arm with a flat square surface measuring 2" X 2" will apply pressure on the bridge deck. The pressure (load) will continue until the bridge breaks or fails to accept additional loading. The software program connected to the testing device will automatically calculate a score. The bridge with the highest failure load to bridge weight ratio will win the contest.

Failure load is determined under any of these conditions: the bridge breaks, the bridge deflects (bends) more than 0.5" from horizontal, or until the maximum load is reached.

Scoring Equation: Bridge score equals the failure load divided by the weight of the bridge. Bridge inspection includes weighing the bridge. **Example #1:** At 100 pounds of load the bridge breaks (failure load). The bridge weighs 0.50 pounds. This equals a score of 200 points (100/0.50=200). **Example #2:** At 200 pounds of load the bridge deflection exceeds 0.5" (failure load). The bridge weighs 0.75 pounds. This equals a score of 267 points (200/0.75=267).

BRIDGE INSPECTION: After an individual or team checks-in on contest day, Contest Officials weigh the bridge and inspect it for meeting requirements in Rule 1 Allowable Materials and Rule 2 Design Requirements. Bridges not meeting requirements are disqualified from competing for awards; however, the bridge can be tested if it fits on the bridge testing equipment. All judging and bridge disqualifications will be conducted by the Bridge Contest Officials. All decisions are final.

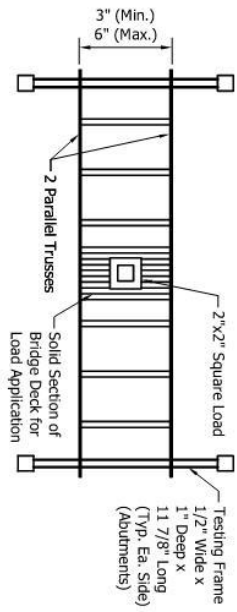

PLAN (TOP VIEW)

Bridges shown are for illustrative purposes only - Students are free to pick any design they choose provided the design meets the stated rules

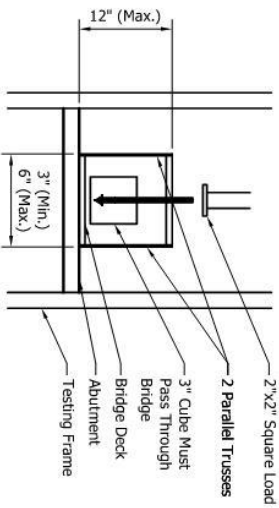

END VIEW

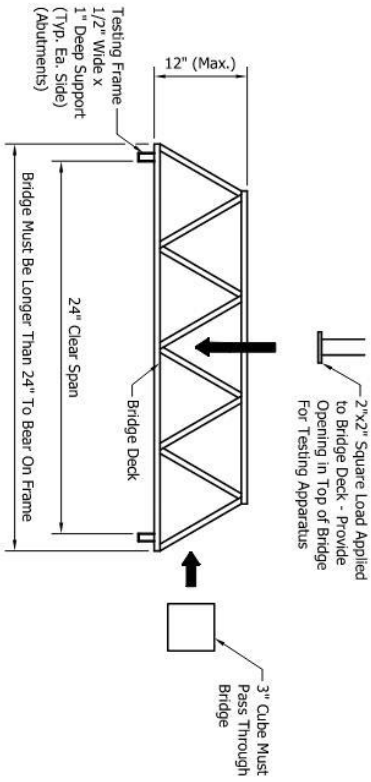

ELEVATION (SIDE VIEW)
Truss Above Deck

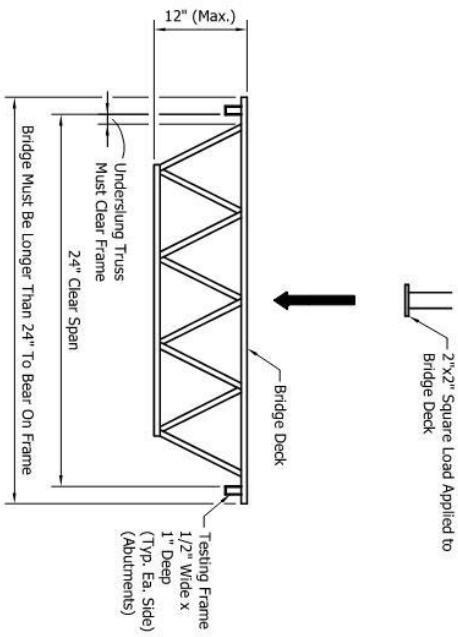

ELEVATION (SIDE VIEW)
Truss Below Deck